



NOAA FISHERIES SERVICE

Pacific Islands
Regional Office

Compliance Guide

Reducing and Mitigating Interactions between Seabirds and Hawaii-Based Longline Fishing

revised July 23, 2010

This guide summarizes how to comply with seabird regulations published in the *Federal Register* on December 19, 2005 (70 FR 75075). These measures are intended to reduce interactions between seabirds and Hawaii-based longline fishing vessels. This guide provides information only about the rule published on December 19, 2005. There are additional requirements for seabird avoidance and mitigation. For the complete set of applicable Federal fishing regulations, please refer to Title 50 of the Code of Federal Regulations, Parts 600 and 665 (50 CFR parts 600 and 665).

Regulations are subject to change, so fishermen must familiarize themselves with the most recent changes and are responsible to comply with them. Any discrepancies between this compliance guide and the regulations will be resolved in the favor of the regulations published in the *Federal Register* (70 FR 75075, December 19, 2005). This compliance guide is issued in accordance with Section 212 of the Small Business Regulatory Enforcement Fairness Act of 1996: title II of Public Law 104-121.

Q1. Who is affected by the regulations?

The regulations apply to owners and operators of vessels that are registered for use under a Hawaii longline limited access permit.

Q2. When did the regulations take effect, and for how long are they effective?

The seabird regulations took effect on January 18, 2006, and will remain in effect until they are revised or removed by the National Marine Fisheries Service (NMFS).

Q3. What is the purpose of these regulations?

The regulations are intended to reduce interactions between seabirds and longline fishing. The regulations implement fishing gear and operational requirements to reduce the likelihood of birds being accidentally hooked, entangled, and killed during fishing operations. NMFS, the Western Pacific Fishery Management Council, and the fishing industry collaborated on research to test these seabird deterrent measures, and NMFS has approved and implemented them.

Q4. What general types of requirements does this final rule contain?

- Implementation of a requirement to either side-set, or use a combination of other seabird mitigation measures; and
- Modification to the requirement for strategic offal discards.

Q5. Where do the regulations apply?

The regulations apply to those vessels that shallow-set (targeting swordfish) anywhere, and to those vessels that deep-set (targeting tuna) north of 23° N latitude.

Q6. What are the regulations?

Vessel owners and operators must either side-set their fishing gear following NMFS specifications described below or, if not side-setting, use the suite of alternative measures described below.

Q7. What are the side-setting requirements?

Side-setting deploys longline gear from the side of the vessel rather than from the stern. Permit holders that choose to side-set may do so with no additional seabird deterrents. However, all side setting vessels must conform to the following specifications:

- The mainline must be deployed as far forward on the vessel as practicable, but at least 1 m (3.3 ft) forward from the stern of the vessel;
- The mainline and branch lines must be set from the port or the starboard side of the vessel;
- If a mainline shooter is used, the mainline shooter must be mounted as far forward on the vessel as practicable, but at least 1 m (3.3 ft) forward from the stern of the vessel;
- Branch lines must have weights with a minimum weight of 45 g (1.6 oz);
- Weights must be placed on all branch lines within 1 m (3.3 ft) of each hook;
- When seabirds are present, the longline gear must be deployed so that baited hooks remain submerged and do not rise to the sea surface; and
- A bird curtain must be deployed (see figures for examples of construction design). Each bird curtain must consist of the following components:
 - A pole that is fixed to the side of the vessel aft of the line shooter and that is at least 3 m (9.8 ft) long;
 - At least three main streamers attached at regular intervals to the upper 2 m (6.6 ft) of the pole and each of which has a minimum diameter of 20 mm (0.8 in); and
 - Branch streamers attached to each main streamer at the end opposite from the pole, each of which is long enough to drag on the sea surface in the absence of wind, and each of which has a minimum diameter of 10 mm (0.4 in).

Examples of design elements for the bird curtain. Modified from Gilman et al. (2003) and Brothers and Gilman (2005).

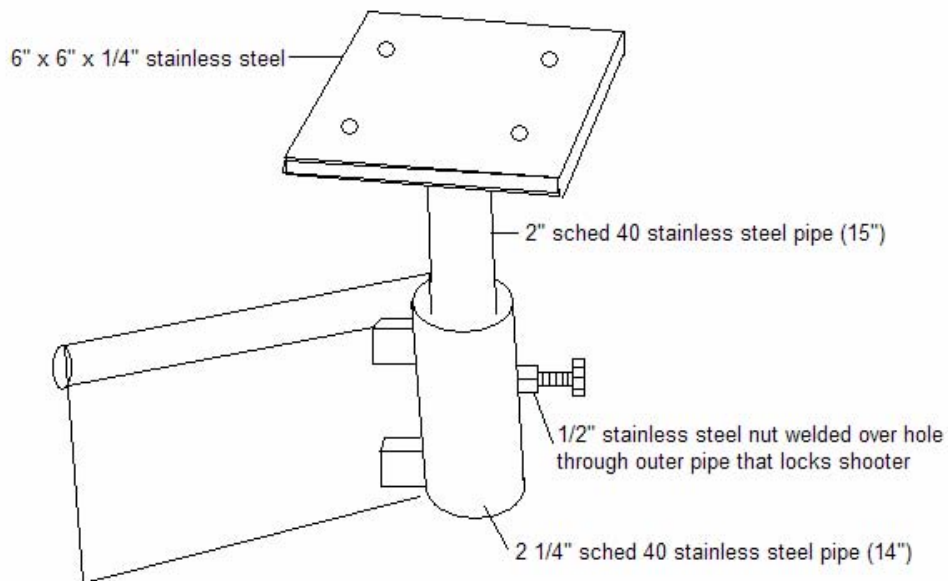
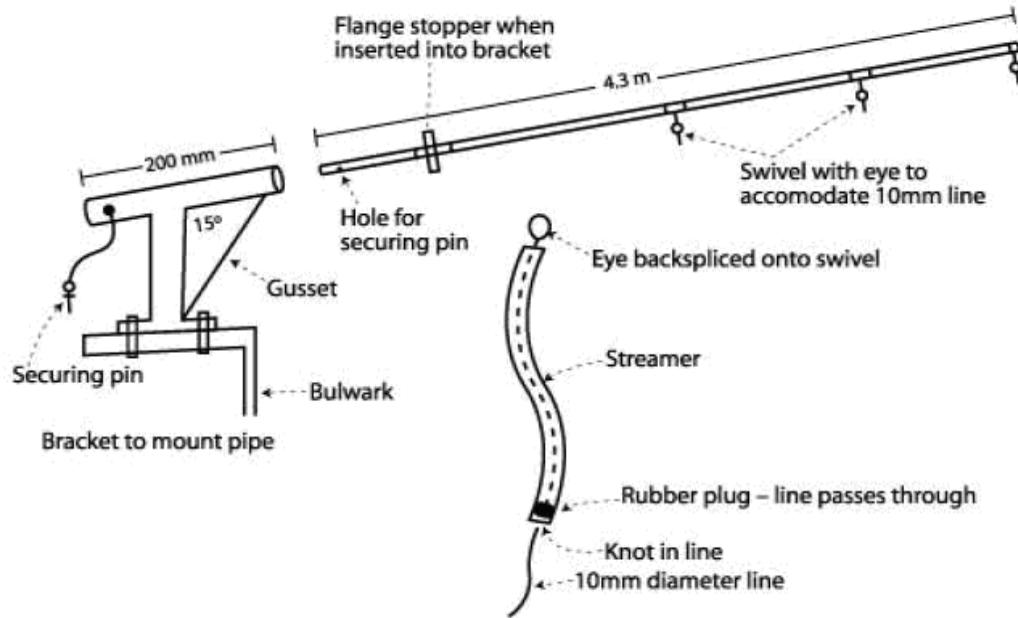

(a) Swivel base for mainline shooter

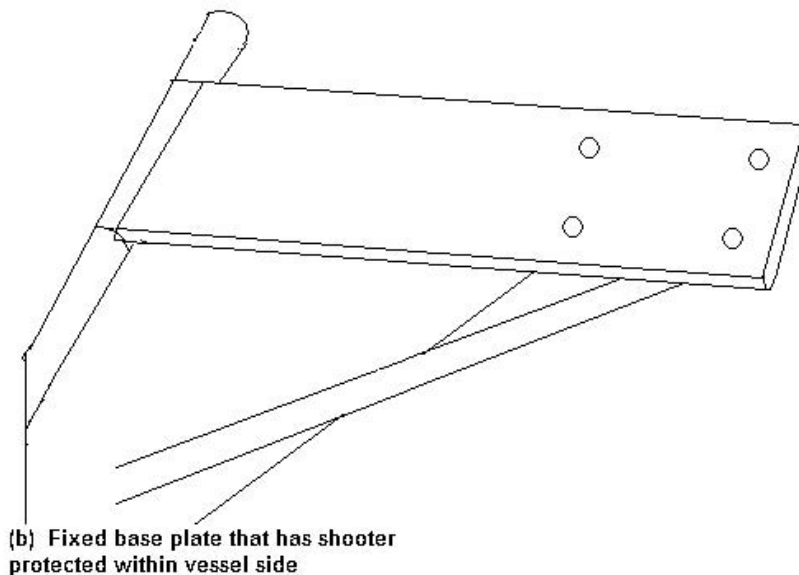

Q8. What is the alternative to side-setting?

The alternative to side-setting is to use a combination of currently-required measures specified by NMFS. This combination includes all of the following:

- Strategic Offal Discards. Discharge fish and fish parts (offal) or spent bait while setting and hauling longline gear on the opposite side of the vessel from where the longline gear is being set and hauled, when seabirds are present; and
- Thawed and Blue Dyed Bait.
 - Use completely thawed bait that has been dyed blue to an intensity level specified by a color quality control card issued by NMFS; and
 - Maintain a minimum of two cans (each sold as 0.45 kg or 1 lb size) containing blue dye on board the vessel.

Q9. What additional requirements apply to vessels that do not side-set?

The following additional requirements apply to vessels that do not side set.

For vessels that deep-set north of 23° N. latitude:

- Use basket-style mainline gear, OR
- If using monofilament nylon mainline gear, employ a line shooter; AND
- Attach at least 45 g (1.6 oz) of weight to each branch line within 1 m (3.3 ft) of each hook.

For vessels that shallow-set anywhere:

Night set. Begin deployment of longline gear at least 1 hr after local sunset and complete the deployment no later than 1 hr before local sunrise, using the minimum vessel lights necessary to conform to navigation rules and best safety practices.

Q10. What modification was made to the requirement for strategic offal discards?

The requirements were modified to specify that offal must be strategically discarded only when seabirds are present.

Q11. What are the penalties for the operator or owner of a vessel who does not follow these regulations?

Penalties are determined on a case-by-case basis; they can include significant administrative, civil, or criminal penalties.

Q12. Where can I obtain additional copies of this guide or receive more information about these regulations?

Sustainable Fisheries Division
Pacific Islands Regional Office
NOAA National Marine Fisheries Service
1601 Kapiolani Blvd., Suite 1110
Honolulu, HI 96814
Phone: (808) 944-2200
www.fpir.noaa.gov/SFD/SFD_regs_2.html

You can also read the notice for this rule in *Federal Register* vol. 70, No. 242, pp. 75075-75080, December 19, 2005.

Search the *Federal Register* at www.gpoaccess.gov/fr/search.html.

Search the Code of Federal Regulations at ecfr.gpoaccess.gov.